

Поглед 1-1

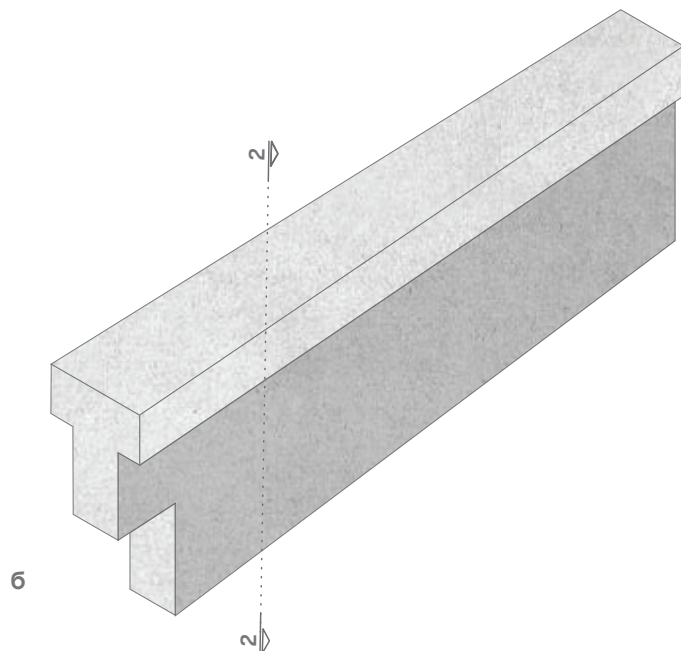

Поглед 2-2

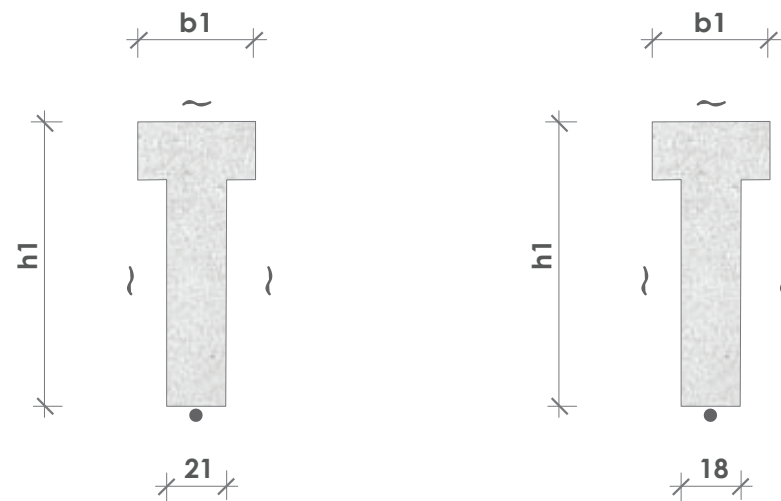
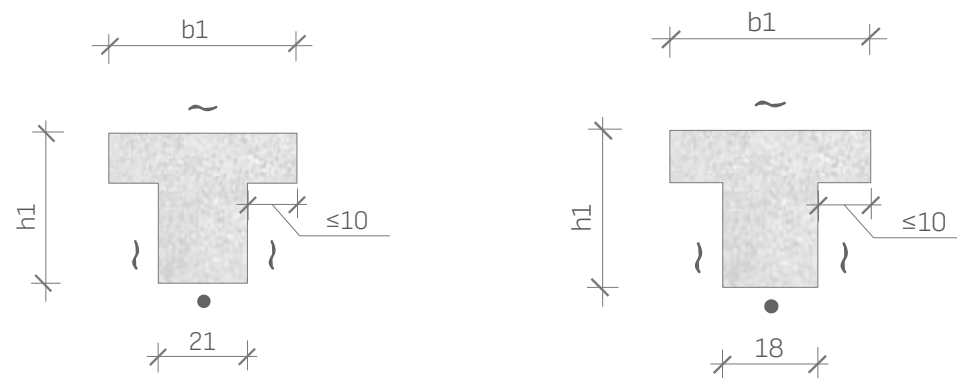

МАТЕРИАЛ	ХАРАКТЕРИСТИКИ
Бетон	C \ge 30/37
Стомана	B500

- a** - пълно стъпване
- б** - понижено стъпване
- *** - по изчисление
- - кофраж
- ~ - свободна повърхност